

POWER LINE FSK TRANSCEIVER

- HALF DUPLEX FREQUENCY SHIFT KEYING (FSK) TRANSCEIVER
- INTEGRATED POWER LINE DRIVER WITH PROGRAMMABLE VOLTAGE AND CURRENT CONTROL
- PROGRAMMABLE INTERFACE:
 - SYNCHRONOUS
 - ASYNCHRONOUS
- SINGLE SUPPLY VOLTAGE (FROM 7.5 UP TO 12.5V)
- VERY LOW POWER CONSUMPTION ($I_q=5$ mA)
- INTEGRATED 5V VOLTAGE REGULATOR (UP TO 100mA) WITH SHORT CIRCUIT PROTECTION
- 8 PROGRAMMABLE TRANSMISSION FREQUENCIES
- PROGRAMMABLE BAUD RATE UP TO 4800BPS
- RECEIVING SENSITIVITY 1 mVRMS
- SUITABLE TO APPLICATION IN ACCORDANCE WITH EN 50065 CENELEC SPECIFICATIONS
- CARRIER OR PREAMBLE DETECTION
- BAND IN USE DETECTION
- PROGRAMMABLE REGISTER WITH SECURITY CHECKSUM
- MAINS ZERO CROSSING DETECTION AND SYNCHRONIZATION

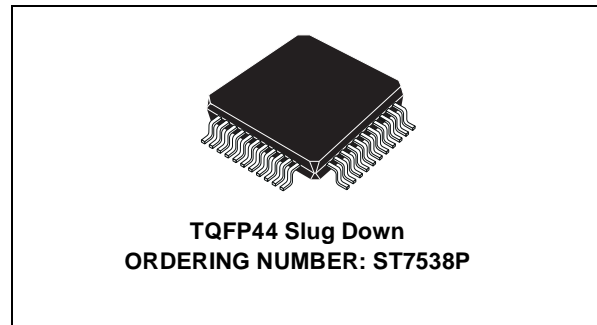

- WATCHDOG TIMER

DESCRIPTION

The ST7538 is a Half Duplex synchronous/asynchronous FSK Modem designed for power line communication network applications. It operates from a single supply voltage and integrates a line driver and a 5V linear regulator. The device operation is controlled by means of an internal register, programmable through the synchronous serial interface. Additional functions as watchdog, clock output, output voltage and current control, preamble detection, time-out, band in use are included. Realized in Multipower BCDV technology that allows to integrate DMOS, Bipolar and CMOS structures in the same chip.

BLOCK DIAGRAM

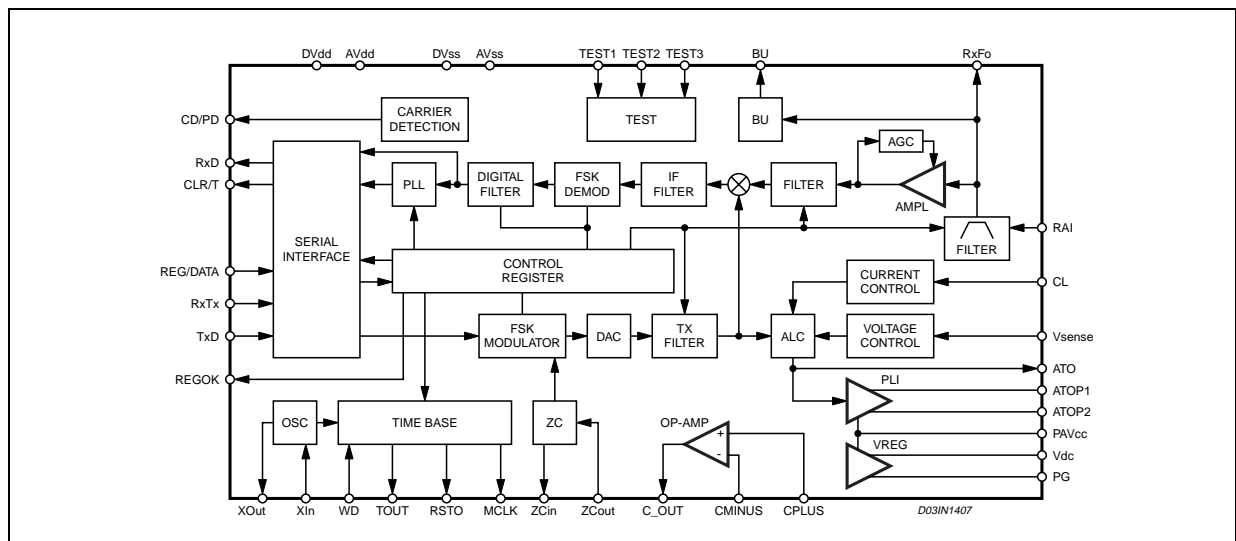

PIN CONNECTION (Top view)

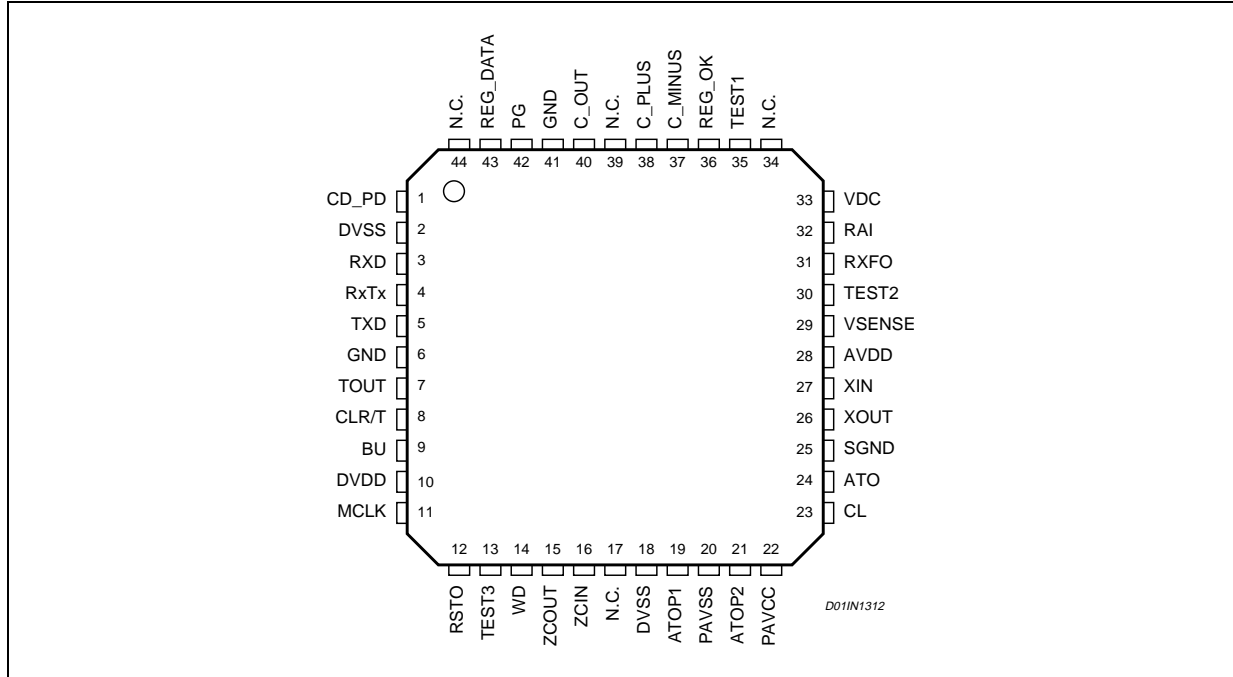

PIN DESCRIPTION

N°	Name	Type	Description
1	CD_PD	Digital/Output	Carrier or Preamble Detect Output. "1" No Carrier or Preamble Detected "0" Carrier or Preamble Detected
2	DVss	Supply	Digital Ground
3	RxD	Digital/Output	RX Data Output.
4	RxTx	Digital/Input with internal pull-up	Rx or Tx mode selection input. "1" - RX Session "0" - TX Session
5	TxD	Digital/Input with internal pull-down	TX Data Input.
6	GND	Supply	Substrate Ground (same function as PIN 41)
7	TOUT	Digital/Output	TX Time Out Event Detection "1" - Time Out Event Occurred "0" - No Time-out Event Occurred
8	CLR/T	Digital/Output	Synchronous Mains Access Clock or Control Register Access Clock
9	BU	Digital/Output	Band in use Output. "1" Signal within the Programmed Band "0" No Signal within the Programmed Band
10	DVdd	Supply	Digital Supply Voltage
11	MCLK	Digital/Output	Master Clock Output
12	RSTO	Digital/Output	Power On or Watchdog Reset Output
13	TEST 3	Digital/Input with internal pull-down	Test Input. Must be connected to DVss during Normal Operation

PIN DESCRIPTION (continued)

N°	Name	Type	Description
14	WD	Digital/Input with internal pull-up	Watchdog input. The Internal Watchdog Counter is cleared on the falling edges.
15	ZCOUT	Digital/Output	Zero Crossing Detection Output
16	ZCIN ¹	Analog/Input	Zero Crossing AC Input.
17	NC	Floating	Must be connected to DVss.
18	DVss	Supply	Digital Ground
19	ATOP1	Power/Output	Power Line Driver Output
20	PAVss	Supply	Power Analog Ground
21	ATOP2	Power/Output	Power Line Driver Output
22	PAV _{CC}	Supply	Power Supply Voltage
23	CL ²	Analog/Input	Current Limiting Feedback. A resistor between CL and AVss sets the PLI Current Limiting Value
24	ATO	Analog/Output	Small Signal Analog Transmit Output
25	SGND	Supply	Analog Signal Ground
26	XOUT	Analog I/O	Crystal Output- External Clock Input
27	XIN	Analog Input	Crystal Oscillator Input
28	AVdd	Supply	Analog Power supply.
29	V _{sense} ³	Analog/Input	Output Voltage Sensing input for the voltage control loop
30	TEST2	Analog/Input	Test Input must be connected SGND
31	RxFO	Analog/Output	Receiving Filter Output
32	RAI	Analog/Input	Receiving Analog Input
33	VDC	Power	5V Voltage Regulator Output
34	NC	floating	Must Be connected to DVss.
35	TEST1	Digital/Input with internal pull-down	Test input. Must Be connected to DVss.
36	REGOK	Digital/Output	Security checksum logic output "1" - Stored data Corrupted "0" - Stored data OK
37	C_MINUS ⁴	Analog/Input	Op-amp Inverting Input.
38	C_PLUS ⁵	Analog/Input	Op-amp Not Inverting Input.
39	NC	floating	Must Be connected to DVss
40	C_OUT	Analog/Output	Op-amp Output
41	GND	Supply	Substrate Ground (same function as PIN 6)
42	PG	Digital/Output	Power Good logic Output "1" - VDC is above 4.5V "0" - VDC is below 4.25V
43	REG_DATA	Digital/Input with internal pull-down	Mains or Control Register Access Selector "1" - Control Register Access "0" - Mains Access
44	NC	floating	Must be connected to DVss.

<1> If not used this pin must be connected to VDC

<2> Cannot be left floating

<3> Cannot be left floating

<4> If not used this pin must be connected to VDC

<5> If not used this pin must be tied low (SGND or PAVss or DVss)

ABSOLUTE MAXIMUM RATINGS

Symbol	Parameter	Value	Unit
PAV _{CC}	Power Supply Voltage	-0.3 to +14	V
AV _{dd}	Analog Supply Voltage	-0.3 to +5.5	V
DV _{dd}	Digital Supply Voltage	-0.3 to +5.5	V
AV _{SS} /DV _{SS}	Voltage between AV _{SS} and DV _{SS}	-0.3 to +0.3	V
V _I	Digital input Voltage	DV _{SS} - 0.3 to DV _{dd} +0.3	V
V _O	Digital output Voltage	DV _{SS} - 0.3 to DV _{dd} +0.3	V
I _o	Digital Output Current	-2 to +2	mA
V _{sense}	Voltage Range at Vsense Input	AV _{SS} - 0.3 to AV _{dd} +0.3	V
RAI	Voltage Range at RAI Input	-AV _{dd} - 0.3 to AV _{dd} +0.3	V
ATO	Output Current at ATO Output	-2 to +2	mA
ATO	Voltage range at ATO Output	AV _{SS} - 0.3 to AV _{dd} +0.3	V
ATOP1,2	Voltage range at Powered ATO Output	AV _{SS} - 0.3 to +PAV _{CC} +0.3	V
ATOP	Powered ATO Output Current	400	mARms
T _{amb}	Operating ambient Temperature	-40 to +85	°C
T _{stg}	Storage Temperature	-50 to 150	°C
ATOP1 Pin	Maximum Withstanding Voltage Range Test Condition: CDF-AEC-Q100-002- "Human Body Model" Acceptance Criteria: "Normal Performance"	±1500	V
ATOP2 Pin		±1000	V
Other pins		±2000	V

THERMAL DATA

Symbol	Parameter	TQFP44 with slug	Unit
R _{th-j-amb1}	Maximum Thermal Resistance Junction-Ambient Steady State(*)	35	°C/W
R _{th-j-amb2}	Maximum Thermal Resistance Junction-Ambient Steady State(**)	50	°C/W

(*) Mounted on Multilayer PCB with a dissipating surface on the bottom side of the PCB

(**) It's the same condition of the point above, without any heatsinking surface on the board.

ELECTRICAL CHARACTERISTICS(AV_{CC} = DV_{CC} = +5V, PAV_{CC} = +9 V, PAV_{SS}, SGND = DV_{SS} = 0V, -40°C ≤ Tamb ≤ 85°C, unless otherwise specified)

Symbol	Parameter	Test Condition	Min.	Typ.	Max.	Unit
AV _{CC} , DV _{CC}	Supply Voltages		4.75	5	5.25	V
PAV _{CC} - DV _{CC}	PAV _{CC} and DV _{CC} Relation during Power-Up Sequence	DV _{CC} < 4.75V	0.1		1.2	V
PAV _{CC} - AV _{CC}	PAV _{CC} and DV _{CC} Relation during Power-Up Sequence	AV _{CC} < 4.75V	0.1		1.2	V
PAV _{CC}	Power Supply Voltage		7.5		12.5	V
	Max allowed slope during Power-Up				10	V/ms
AI _{CC} + DI _{CC}	Input Supply Current	Transmission & Receiving mode		5	7	mA
I PAV _{CC}	Powered Analog Supply Current	TX mode (no load)		30	50	mArms
		RX mode		500	1000	μA
		Maximum total current			370	mArms
Digital I/O						
V _{IH}	High Logic Level Input Voltage		2			V
V _{IL}	Low Logic Level input Voltage				0.8	V
V _{OH}	High Logic Level Output Voltage	I _{OH} = -2mA	3.5			V
V _{OL}	Low Logic Level Output Voltage	I _{OL} = 2mA			0.4	V
Oscillator						
V _{IHX}	XIN High Level Input Voltage	External Clock	3			V
V _{ILX}	XIN Low Level Input Voltage	External Clock			2	V
DC	XTAL Clock Duty Cycle	External Clock	40		60	%
Xtal	Crystal Oscillator frequency		16			MHz
Tclock	Oscillator Period (1/Xtal)		62.5			ns
Xtal _{ESR}	External Oscillator ESR Resistance				40	Ohm
Xtal _{CL}	External Oscillator Stabilization Capacitance				16	pF
Transmitter						
IATOP	Output Transmitting Current in programmable current limiting	V _{sense} connected though a 100pF cap to GND; R _{cl} =1.85kΩ; R _{LOAD} = 1Ω (as in fig. 13)	250	310	370	mArms
V _{ATO}	Max Carrier Output AC Voltage	R _{CL} = 1.85kΩ V _{sense} =0V	1.75	2.3	3.5	V _{PP}
V _{ATODC}	Output DC Voltage on ATO		1.7	2.1	2.5	V
HD _{2ATO}	Second Harmonic Distortion on ATO	V _{ATO} = 2V _{PP} ; F _c =86KHz		-55	-42	dB
HD _{3ATO}	Third Harmonic Distortion on ATO	V _{ATO} = 2V _{PP} ; F _c =86KHz		-52	-49	dB
V _{ATOP(AC)}	Max Carrier Output AC Voltage for each ATOP1 and ATOP2 pins	R _{CL} = 1.85kΩ V _{sense} =0V $PAV_{CC} \geq \frac{V_{ATOP(AC)}}{2} + 7.5V$	3.5	4.6	6	V _{pp}
V _{ATOP(DC)}	Output DC Voltage on ATOP1 and ATOP2 pins		3.5	4.2	5	V

ELECTRICAL CHARACTERISTICS (continued)(AV_{CC} = DV_{CC} = +5V, PAV_{CC} = +9 V, PAV_{SS}, SGND = DV_{SS} = 0V, -40°C ≤ T_{amb} ≤ 85°C, unless otherwise specified)

Symbol	Parameter	Test Condition	Min.	Typ.	Max.	Unit
HD2 _{ATOP}	Second Harmonic Distortion on each ATOP1 and ATOP2 pins	V _{ATOP} = 4V _{PP} No Load		-55	-42	dB
		V _{ATOP} = 4V _{PP} R _{LOAD} = 50Ω (Differential) Carrier Frequency: 132.05KHz		-65	-53	dB
HD3 _{ATOP}	Third Harmonic Distortion on each ATOP1 and ATOP2 pins	V _{ATOP} = 4V _{PP} No Load.		-56	-49	dB
		V _{ATOP} = 4V _{PP} R _{LOAD} = 50Ω (Differential) Carrier Frequency: 132.05KHz		-65	-52	dB
V _{ATOP}	Accuracy with Voltage Control Loop Active	R _{CL} = 0Ω	-1		+1	GST
GST	ALC Gain Step Control loop gain step		0.6	1	1.4	dB
DRNG	ALC Dynamic Range			30		dB
V _{CLTH}	Voltage control loop reference threshold on V _{sense} pin	Figure 13	170	190	210	mV _{PK}
V _{CLHYST}	Hysteresis on Voltage loop reference threshold	Figure 13		+/-19		mV
C _{CLTH}	Current control loop reference threshold on C _{sense} pin	Figure 13	1.80	1.90	2.00	V
C _{CLHYST}	Hysteresis on Voltage loop reference threshold	Figure 13	210	250	290	mV
V _{SENSE}	VSENSE Input Impedance			36		KΩ
T _{RXTX}	Carrier Activation Time	Figure 16 - 600 Baud Xtal=16MHz	0.01		1.6	ms
		Figure 16- 1200 Baud Xtal=16MHz	0.01		800	μs
		Figure 16- 2400 Baud Xtal=16MHz	0.01		400	μs
		Figure 16- 4800 Baud Xtal=16MHz	0.01		200	μs
TALC	Carrier Stabilization Time From STEP 16 to zero or From step 16 to step 31,	Figure 16. Xtal =16MHz			3.2	ms
T _{ST}	Tstep	Figure 16 Xtal =16MHz			200	μs
Receiver						
V _{IN}	Input Sensitivity (Normal Mode)			1	2	mV _{rms}
	Input Sensitivity (High Sens.)			500		μV _{rms}
V _{IN}	Maximum Input Signal				2	V _{rms}
R _{IN}	Input Impedance		80	100	140	kΩ
V _{CD}	Carrier Detection Sensitivity (Normal Mode)			1	2	V _{rms}
	Carrier Detection Sensitivity (High Sensitivity Mode)			500		V _{rms}
V _{BU}	Band in Use Detection Level			77	85	dB/ μV _{rms}

ELECTRICAL CHARACTERISTICS (continued)

(AVCC = DVCC = +5V, PAVCC = +9 V, PAVSS, SGND = DVSS = 0V, -40°C ≤ Tamb ≤ 85°C, unless otherwise specified)

Symbol	Parameter	Test Condition	Min.	Typ.	Max.	Unit
Voltage Regulator						
VDC	Linear Regulator Output Voltage	-25<Tj<125 C 0<Io<100mA	4.9	5.05	5.2	V
		-25<Tj<125 C 0<Io<150mA	4.7		5.2	V
	Line Regulation	7.5V<PAVCC<12.5V Idc=10mA		10	50	mV
	Load Regulation	5mA<Idc<100mA Vin=7.5V		20	75	mV
I(VDC)	Linear Regulator Current Limitation		150	180	210	V
UVLO	Input Under Voltage Lock Out Threshold		3.7	3.9	4.1	V
UVLOHYS	UVLO Hysteresis			340		mV
PG	Power Good Output Voltage Threshold on VDC pin		4.3	4.5	4.7	V
PGHYS	PG Hysteresis			250		mV
Other Functions						
TRSTO	Reset Time	See Figure 18; Xtal=16MHz	50			ms
TWD	Watch-dog Pulse Width	See Figure 18		50		ns
TWM	Watch-dog Pulse Period	See Figure 18	50			µs
TWO	Watch-dog Time Out	See Figure 18			1.5	s
TOUT	TX TIME OUT	Control Register Bit 7 and Bit 8 See Figure 17		1 3		s
TOFF	Time Out OFF Time	See Figure 17	125			ms
TOFFD	RxTx 0->1 vs. TOUT Delay	See Figure 17			20	µs
TCD	Carrier Detection Time selectable by register	Control Register bit 9 and bit 10 Figure 10		500 1 3 5		µs ms ms ms
TDCD	CD_PD Propagation Delay	Figure 10		300	500	µs
MCLK	Master Clock Output Selectable by register	Control Register bit 15 and bit 16 see table 6		fclock fclock/2 fclock/4		MHz
BAUD	Baud rate	Control Register bit 3 and bit 4 see table 6		600 1200 2400 4800		Baud
TB	Baud rate Bit Time (=1/BAUD)	Control Register bit 3 and bit 4 see table 6		1667 833 417 208		µs
Zero Crossing Detection						
ZCDEL	Zero Crossing Detection delay (delay between the ZCIN and ZCOUT signals)	Figure 19			1	µs
ZC(LOW)	Zero Crossing Detection Low Threshold		-45		-5	mV

ELECTRICAL CHARACTERISTICS (continued)

(AVcc = DVcc = +5V, PAVcc = +9 V, PAVss, SGND = DVss = 0V, -40°C ≤ Tamb ≤ 85°C, unless otherwise specified)

Symbol	Parameter	Test Condition	Min.	Typ.	Max.	Unit
ZC(HIGH)	Zero Crossing Detection High Threshold		5		+45	mV
ZC(OFFSET)	Zero Crossing Offset		-20		+20	mV
Operational Amplifier						
CO _{UT} (Sync)	Max Sync Current		15	28	45	mA
CO _{UT} (Source)	Max Source Current		-30	-20	-10	mA
C _{IN} (Offset)	Input Terminals OFFSET		-38		+38	mV
GBWP	Gain Bandwidth Product		6	7	9	MHz
Serial Interface						
T _S	Setup Time	see figure 3, 5, 6, 7 & 8			5	ns
T _H	Hold Time	see figure 3, 5, 6, 7 & 8			2	ns
T _{CR}	CLR/T vs. REG_DATA or RxTx	see figure 3, 5, 6, 7 & 8			T _B /4	
T _{CC}	CLR/T vs. CLR/T	see figure 3, 5, 6, 7 & 8	T _B		2*T _B	
T _{DS}	Setup Time	see figure 3, 5, 6, 7 & 8	T _B /4		T _B /2	
T _{DH}	Hold Time	see figure 3, 5, 6, 7 & 8	T _B /4		T _B /2	
T _{CRP}		see figure 4	T _H		T _B /2	

FUNCTIONAL DESCRIPTION

Carrier Frequencies

ST7538 is a multi frequency device: eight programmable Carrier Frequencies are available (see table 1). Only one Carrier could be used a time. The communication channel could be varied during the normal working Mode to realize a multifrequency communication.

Selecting the desired frequency in the Control Register the Transmission and Reception filters are accordingly tuned.

Table 1.

FCarrier	F (KHz)
F0	60
F1	66
F2	72
F3	76
F4	82.05
F5	86
F6	110
F7 ⁽¹⁾	132.5

Baud Rates

ST7538 is a multi Baud rate device: four Baud Rate are available (See table 2).

Table 2.

Baud Rate [Baud]	ΔF ⁽²⁾ (Hz)	Deviation ⁽³⁾
600	600	1 ⁽⁴⁾
1200	600 1200	0.5 1
2400 ⁽¹⁾	1200 ⁽¹⁾ 2400	0.5 1
4800	2400 4800	0.5 1

Note: 1. Default value
 2. Frequency deviation.
 3. Deviation = $\Delta F /$ (Baud Rate)
 4. Deviation 0.5 Not Allowed

Mark and Space Frequencies

Mark and Space Communication Frequencies are defined by the following formula:

$$F ("0") = F_{Carrier} + [\Delta F]/2$$

$$F ("1") = F_{Carrier} - [\Delta F]/2$$

ΔF is the Frequency Deviation.

With Deviation = "0.5" the difference in terms of frequency between the mark and space tones is half the Baudrate value ($\Delta F=0.5 \cdot B_{Audrate}$). When the Deviation = "1" the difference is the Baudrate itself ($\Delta F=B_{Audrate}$). The minimal Frequency Deviation is 600Hz.

Table 3.

Carrier Frequency (KHz)	Baud Rate	Deviation	Exact Frequency [Hz] (Clock=16MHz)		Carrier Frequency (KHz)	Baud Rate	Deviation	Exact Frequency [Hz] (Clock=16MHz)			
			"1"	"0"				"1"	"0"		
60	600	--			82.05	600	--				
		1	59733	60221			1	81706	82357		
	1200	0.5	59733	60221		1200	0.5	81706	82357		
		1	59408	60547			1	81380	82682		
	2400	0.5	59408	60547		2400	0.5	81380	82682		
		1	58757	61198			1	80892	83171		
	4800	0.5	58757	61198		4800	0.5	80892	83171		
		1	57617	62337			1	79590	84473		
	66	600	--				86	600	--		
			1	65755		66243			1	85775	86263
		1200	0.5	65755		66243		1200	0.5	85775	86263
			1	65430		66569			1	85449	86589
2400		0.5	65430	66569	2400	0.5		85449	86589		
		1	64779	67220		1		84798	87240		
4800		0.5	64779	67220	4800	0.5		84798	87240		
		1	63639	68359		1		83659	88379		
72		600	--			110		600	--		
			1	71777	72266				1	109701	110352
		1200	0.5	71777	72266			1200	0.5	109701	110352
			1	71452	72591				1	109375	110677
	2400	0.5	71452	72591	2400		0.5	109375	110677		
		1	70801	73242			1	108724	111165		
	4800	0.5	70801	73242	4800		0.5	108724	111165		
		1	69661	74382			1	107585	112467		
	76	600	--				132.05	600	--		
			1	75684	76335				1	132161	132813
		1200	0.5	75684	76335			1200	0.5	132161	132813
			1	75358	76660				1	131836	133138
2400		0.5	75358	76660	2400	0.5		131836	133138		
		1	74870	77148		1		131348	133626		
4800		0.5	74870	77148	4800	0.5		131348	133626		
		1	73568	78451		1		130046	134928		



Host Processor Interface

ST7538 exchanges data with the host processor through a serial interface.

The data transfer is managed by REG_DATA and RxTx Lines, while data are exchanged using RxD, TxD and CLR/T lines.

Four are the ST7538 working modes:

- Data Reception
- Data Transmission
- Control Register Read
- Control Register Write

REG_DATA and RxTx lines are level sensitive inputs.

Table 4.

	REG_DATA	RxTx
Data Transmission	0	0
Data Reception	0	1
Control Register Read	1	1
Control Register Write	1	0

■ Mains Access

ST7538 features two type of communication interfaces:

- Asynchronous
- Synchronous

The selection can be done through the internal Control Register.

Figure 1.

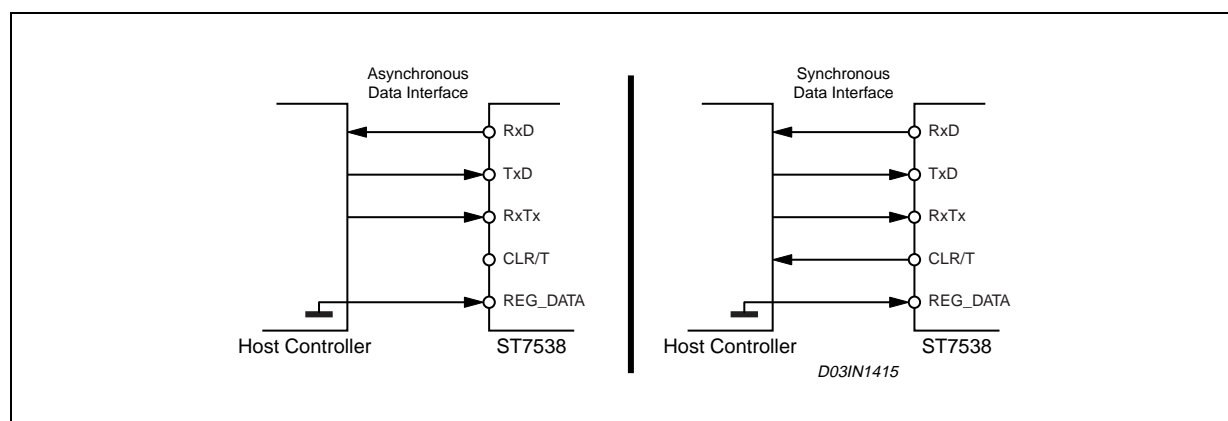

– Asynchronous Mode.

ST7538 allows to interface the Host Controller using a 3 line interface (RXD, TXD & RxTx).

Data are exchange without any auxiliary Clock reference in an Asynchronous mode without adding any protocol bits. The host controller has to recover the clock reference in receiving Mode and control the Bit time in transmission mode. RxD line is forced to a low logic level when no carrier is detected.

– Synchronous mode.

ST7538 allows to interface the host Controller using a four lines synchronous interface (RXD, TXD, CLR/T & RxTx). ST7538 is always the master of the communication and provides the clock reference on CLR/T line.

When ST7538 is in receiving mode an internal PLL recovers the clock reference. Data on RxD line are stable on CLR/T rising Edge.

When ST7538 is in transmitting mode the clock reference is internally generated and data are read on TxD line on CLR/T rising Edge.

If RxTx line is set to “1” & REG_DATA=“0” (Data Reception), ST7538 enters in an Idle State and CLR/T line is forced Low. After T_{cc} time the modem starts providing received data on RxD line.

If RxTx line is set to “0” & REG_DATA=“0” (Data Transmission), ST7538 d in an Idle State and transmission circuitry is switched on. (figure 3). After T_{cc} time the modem starts transmitting data present on TXD line (figure 3) .

Figure 2.

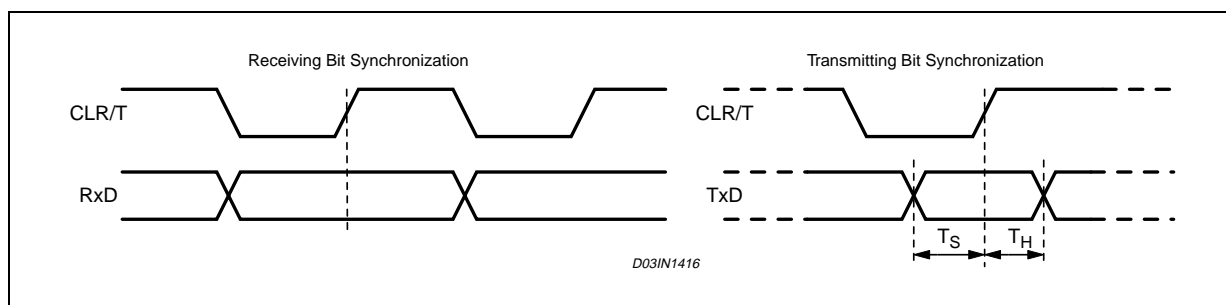
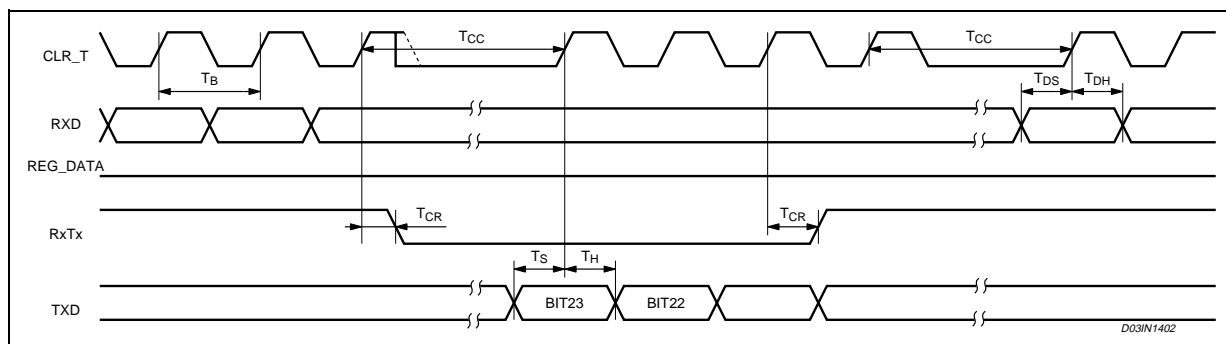

Figure 3. Data Reception -> Data Transmission -> Data reception



PACKET MODE (Only for Reception)

In Packet mode data transmission from ST7538 to Host Controller is done at a higher speed than the Mains one. This function could reduce the efficiency of data exchange process because the Host Controller is involved in data reception for a shorter period of time.

To achieve this function is enabled an internal auxiliary buffer which stores the incoming bits. The buffer is transferred to the host controller when full at the packet rate. The packet rate is programmable and is related to the Mclk clock frequency. The length of the packet can be also programmed through the control register (see table 9) to be 16, 14, 9 or 8 bits.

The packet mode to start working needs two levels of enable. One at the control register level the other at the pin level. TxD is the pin that if forced High enables the Packet Mode Function. According to when TxD is forced high, the next incoming bit is stored inside the internal buffer or delivered on RxD pin. If TxD pin is forced low during a RX session the transceiver starts working in bit mode and the content of the packet buffer is deleted.

Figure 4. Packet Mode Timing

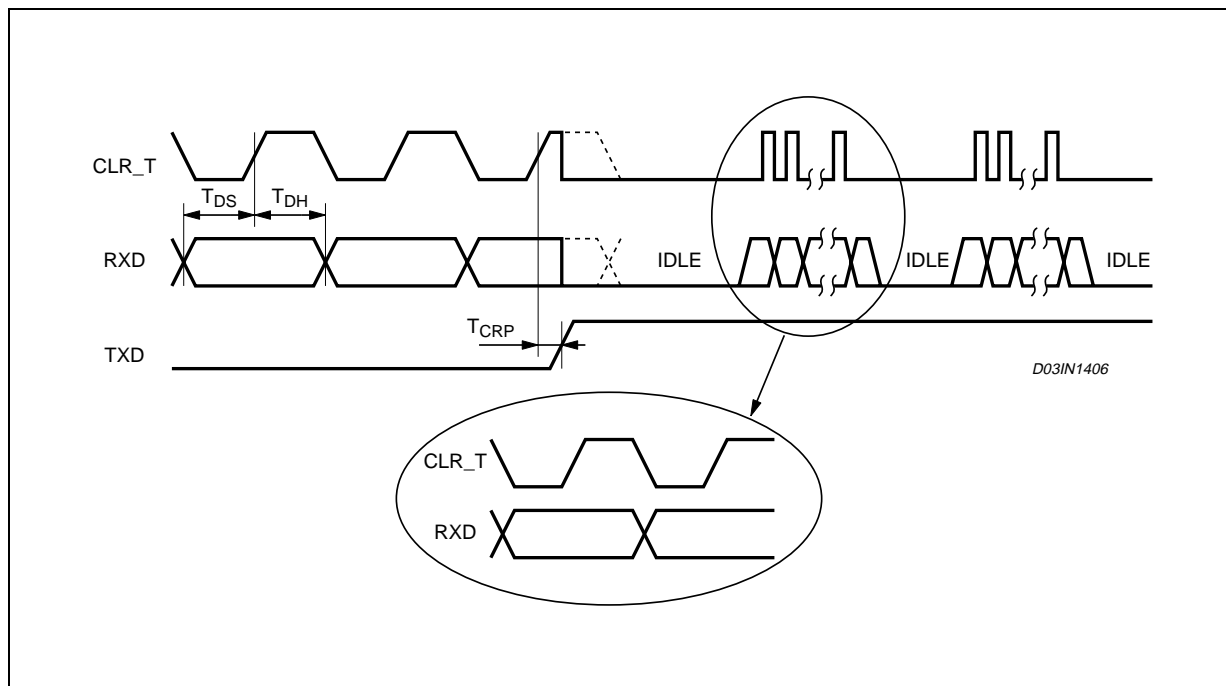

Control Register Access

The communication with ST7538 Control Register is always synchronous. The access is achieved using the same lines of the Mains interface (Rx/D, Tx/D and CLR/T) plus REG_DATA Line.

With REG_DATA = 1 and RxTx=0, the data present on Tx/D are loaded into the Control Register MSB first. The ST7538 sampled the Tx/D line on CLR/T rising edges. The control Register content is updated at the end of the register access section (REG_DATA falling edge). If more than 24 bits are transferred to ST7538 only the latest 24 bits are stored inside the Control Register.

With REG_DATA = 1 and RxTx=1, the content of the Control Register is sent on Rx/D port. The Data on Rx/D are stable on CLR/T rising edges MSB First.

Figure 5. Data Reception → Control Register read → Data Reception Timing Diagram

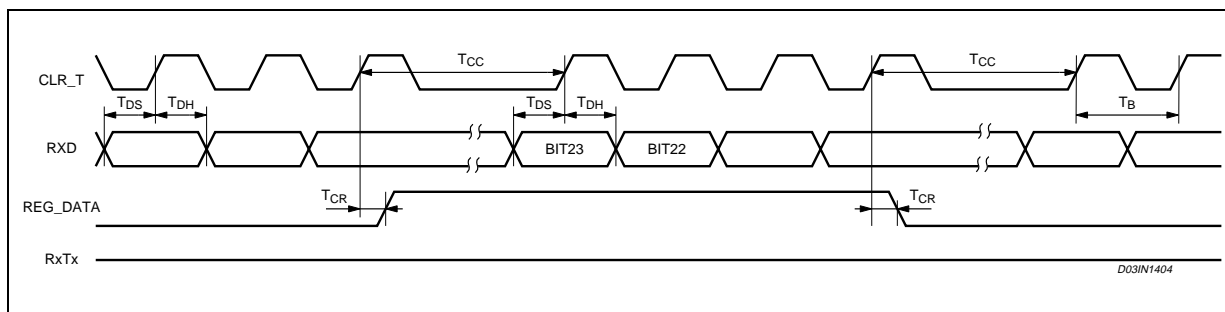

Figure 6. Data Reception → Control Register write → Data Reception Timing Diagram

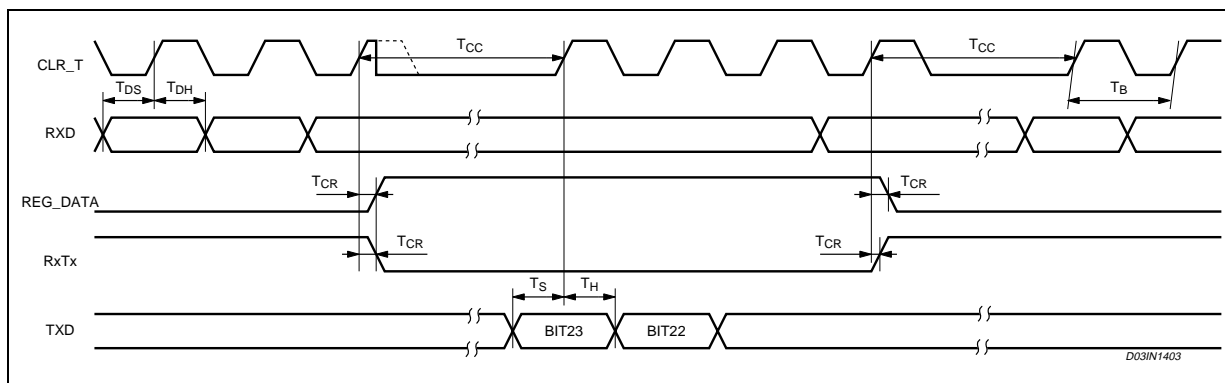

Figure 7. Data Transmission → Control Register read → Data Reception Timing Diagram

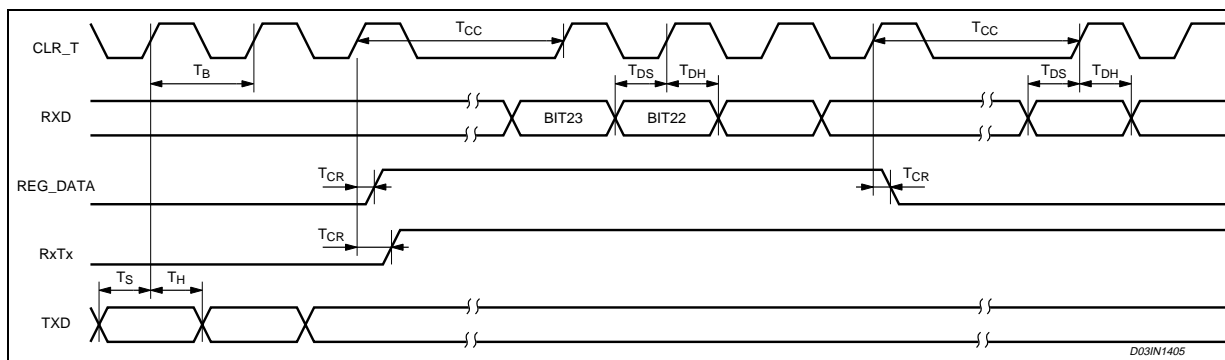
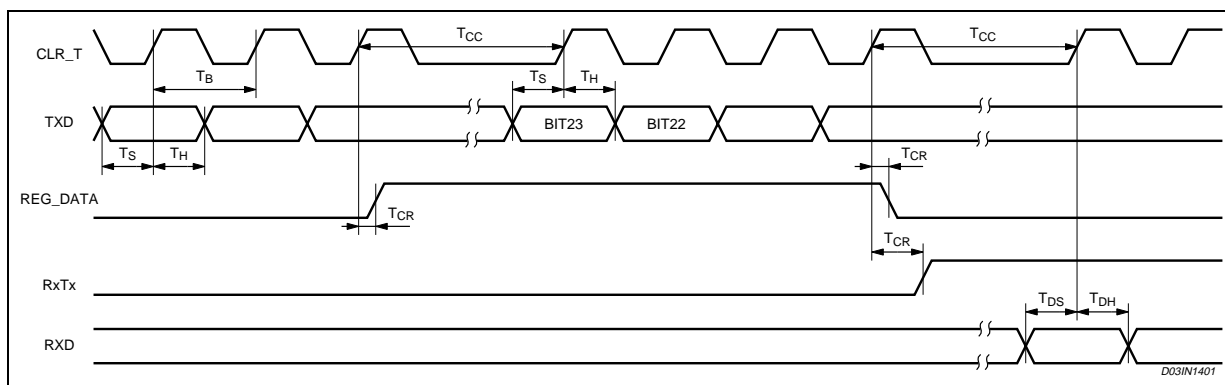

Figure 8. Data Transmission → Control Register Write → Data Reception Timing Diagram



Receiving Mode

The receive section is active when RxTx Pin = "1" and REG_DATA=0.

The input signal is read on RAI Pin using SGND as ground reference and then pre-filtered by a Band pass Filter (+-10KHz). The Pre-Filter can be removed setting one bit in the Control Register. The Input Stage features a wide dynamic range to receive Signal with a Very Low Signal to Noise Ratio. The Amplitude of the applied waveform is automatically adapted by an Automatic Gain Control block (AGC) and then filtered by a Narrow Band Band-Pass Filter centered around the Selected Channel Frequency (+-6K). The resulting signal is down-converted by a mixer using a sinewave generated by the FSK Modulator. Finally an Intermediate Frequency Band Pass-Filter (IF Filter) improves the Signal to Noise ratio before sending the signal to the FSK demodulator. The FSK demodulator then send the signal to the RX Logic for final digital filtering. Digital filtering Removes Noise spikes far from the BAUD rate frequency and Reduces the Signal Jitter. RxD Line is forced at logic level "0" when neither mark or space frequencies are detected on RAI Pin. Mark and Space Frequency in Receiving Mode must be distant at least BaudRate/2 to have a correct demodulation.

While ST7538 is in Receiving Mode (RxTx pin = "1"), the transmit circuitry, Power Line Interface included, are turned off. This allows the device to achieve a very low current consumption (5 mA typ). In Receiving mode ATOP2 pin is internally connected to PAVSS.

■ High Sensitivity Mode

It is possible to increase ST7538 Receiving Sensitivity setting to "1" the High Sensitivity Bit of Control Register. This Function allows to increase the communication reliability when the ST7538 sensitivity is the limiting factor.

■ Synchronization Recovery System (PLL)

ST7538 embeds a Clock Recovery System to feature a Synchronous data exchange with the Host Controller.

The clock recovery system is realized by means of a second order PLL. Data on the data line (RxD) are stable on CLR/T line rising edge (CLR/T Falling edge synchronized to RxD line transitions \pm LOCK-IN Range).

The PLL Lock-in and Lock-out Range is $\pm\pi/2$. When the PLL is in the unlock condition, CLR/T and RxD lines are forced to a low logic level.

When PLL is in unlock condition it is sensitive to RxD Rising and Falling Edges. The maximum number of transition required to reach the lock-in condition is 5. When in lock-in condition the PLL is sensitive only to RxD rising Edges to reduce the CLR/T Jitter.

ST7538 PLL is forced in the un-lock condition, when more than 32 equal symbols are received.

Figure 9.

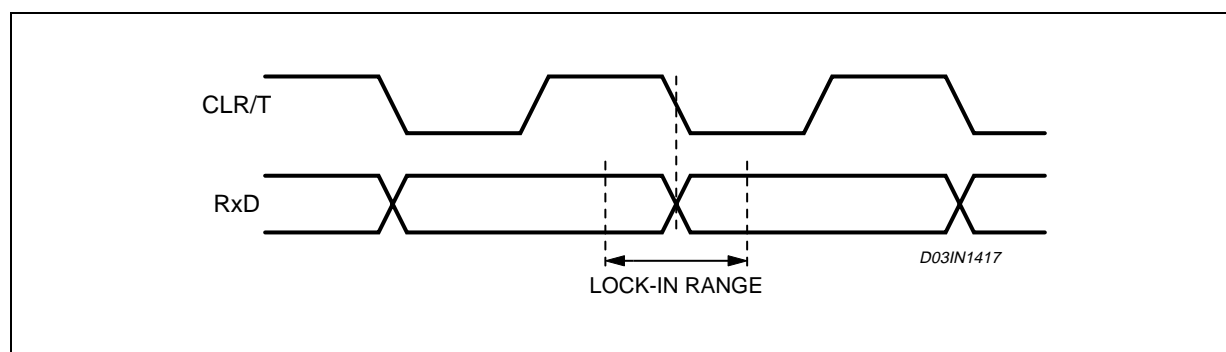

■ **Carrier/Preamble Detection**

The Carrier/Preamble Block is a digital Frequency detector Circuit. It can be used to manage the MAINS access and to detect an incoming signal. Two are the possible setting:

- Carrier Detection
- Preamble Detection

CARRIER DETECTION: The Carrier/Preamble detection Block notifies to the host controller the presence of a Carrier when it detects on the RAI Input a signal with an harmonic component close to the programmed Carrier Frequency. The CD_PD signal sensitivity is identical to the data reception sensitivity (1mVrms Typ. in Normal Sensitivity Mode).

The CD_PD line is forced to a logic level low when a Carrier is detected.

PREAMBLE DETECTION: The Carrier/Preamble detection Block notifies to the host controller the presence of a Carrier modulated at the Programmed Baud Rate for at least 4 Consecutive Symbols ("1010" or "0101" are the symbols sequences detected).

CD_PD line is forced low till a Carrier signal is detected and PLL is in the lock-in range.

To reinforce the effectiveness of the information given by CD_PD Block, a digital filtering is applied on Carrier or Preamble notification signal (See Control Register Paragraph). The Detection Time Bits in the Control Register define the filter performance. Increasing the Detection Time reduced the false notifications caused by noise on main line. The Digital filter adds a delay to CD_PD notification equal to the programmed Detection Time. When the carrier frequency disappears, CD_PD line is held low for a period equal to the detection time and then forced high.

Figure 10. CD_PD Timing during RX

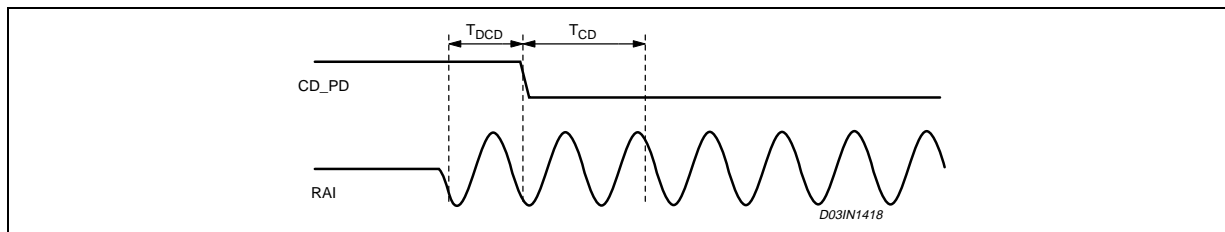
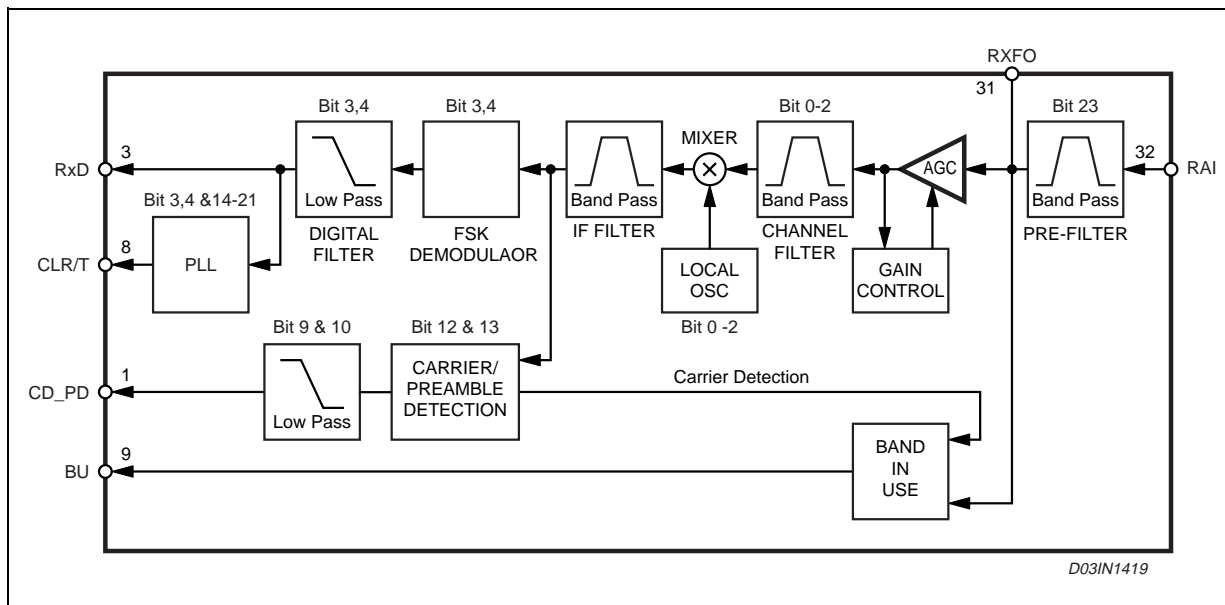

Figure 11. Receiving Path Block Diagram



Transmission Mode

The transmit mode is set when RxTx Pin = "0" and REG_DATA Pin = "0". In transmitting mode the FSK Modulator and the Power Line Interface are turned ON. The transmit Data (TXD) enter synchronously or asynchronously to the FSK modulator.

- Host Controller Synchronous Communication Mode: on CLR/T rising edge, TXD Line Value is read and sent to the FSK Modulator. ST7538 Manage the Transmission timing according to the BaudRate Selected
- Host Controller Asynchronous Communication Mode: TXD data enter directly to the FSK Modulator. The Host Controller Manages the Transmission timing

In both conditions no Protocol Bits are added by ST7538.

The FSK frequencies are synthesized in the FSK modulator from a 16 MHz crystal oscillator by direct digital synthesis technique. The frequencies Table in different Configuration is reported in Table 3. The frequencies precision is same as external crystal one's.

In the analog domain, the signal is filtered in order to reduce the output signal spectrum and to reduce the harmonic distortion. The transition between a symbol and the following is done at the end of the on-going half FSK sinewave cycle.

Figure 12.

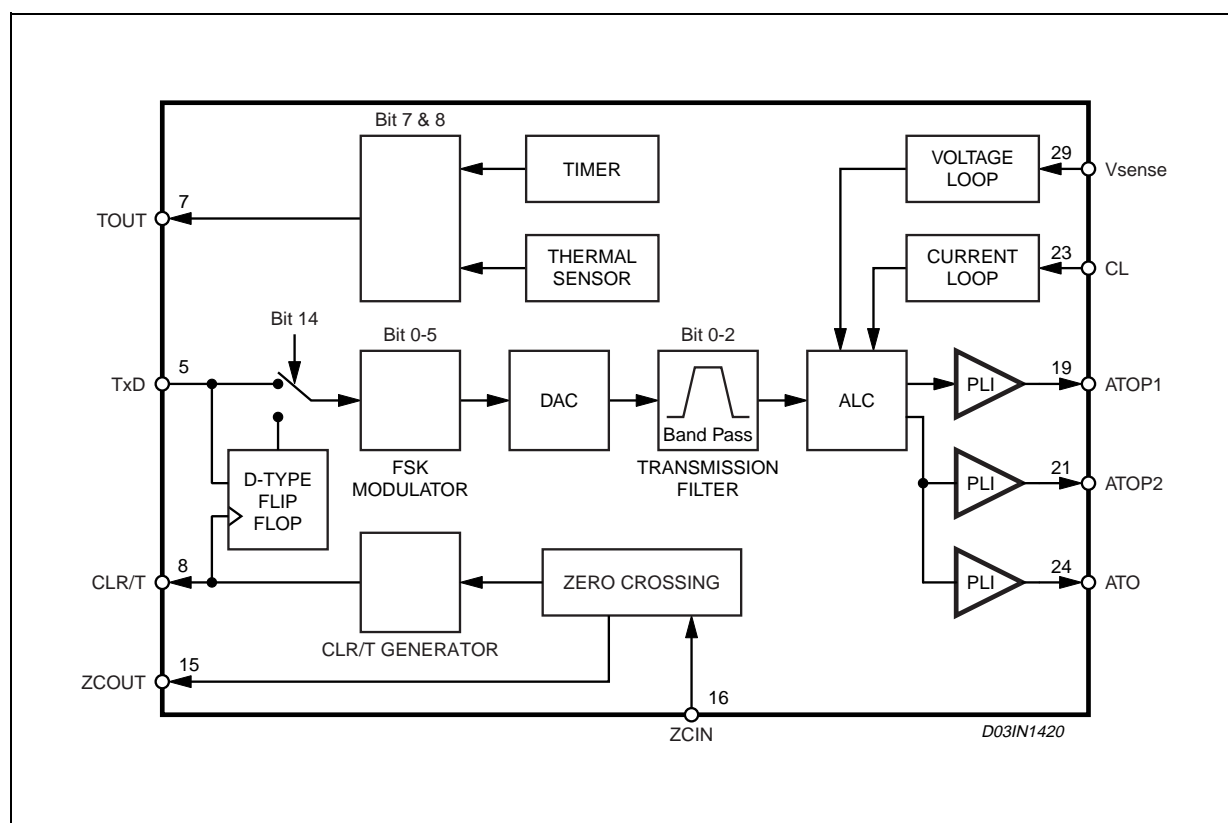

■ **Automatic Level Control (ALC)**

The Automatic Level Control Block (ALC) is a variable gain amplifier (with 32 non linear discrete steps) controlled by two analog feed backs acting at the same time. The ALC gain range is 0dB to 30 dB and the gain change is clocked at 5KHz. Each step increases or reduces the voltage of 1dB (Typ).

Two are the control loops acting to define the ALC gain:

- A Voltage Control loop
- A Current Control Loop

The Voltage control loop acts to keep the Peak-to-Peak Voltage constant on Vsense. The gain adjustment is related to the result of a peak detection between the Voltage waveform on Vsense and two internal Voltage references.

- If $V_{sense} < V_{CL_{TH}} - V_{CL_{HYST}}$ The next gain level is increased by 1 step
- If $V_{CL_{TH}} - V_{CL_{HYST}} < V_{sense} < V_{CL_{TH}} + V_{CL_{HYST}}$ No Gain Change
- If $V_{sense} > V_{CL_{TH}} + V_{CL_{HYST}}$ The next gain level is decreased by 1 step

The Current control loop acts to limit the maximum Peak Output current inside ATOP1 and ATOP2. The current control loop acts through the voltage control loop decreasing the Output Peak-to-Peak Amplitude to reduce the Current inside the Power Line Interface.

The current sensing is done by mirroring the current in the High side MOS of the Power Amplifier (not dissipating current Sensing). The Output Current Limit (up to 400mA_{peak}), is set by means of an external resistor (R_{CL}) connected between CL and PAV_{ss}. The resistor converts the current sensed into a voltage signal. The Peak current sensing block works as the Output Voltage sensing Block:

- If $V(CL) < CCL_{TH} - CCL_{HYST}$ Voltage Control Loop Acting
- If $CCL_{TH} - CCL_{HYST} < V(CL) < CCL_{TH} + CCL_{HYST}$ No Gain Change
- If $V(CL) > CCL_{TH} + CCL_{HYST}$ The next gain level is decreased by 1 step

Figure 13 shows the typical connection of Current and Voltage control loops.

Figure 13. Voltage and Current Feedback external interconnection Example

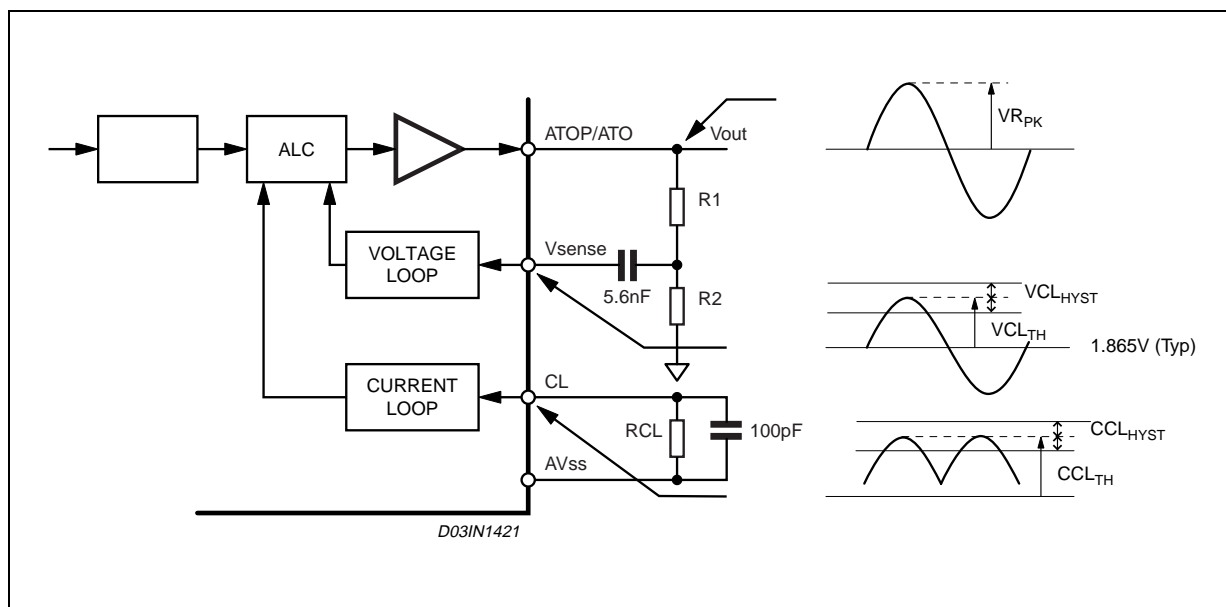

Voltage Control Loop Formula

$$VR_{PK} \cong \frac{R_1 + R_2}{R_2} \cdot (V_{CL_{TH}} \pm V_{CL_{HYST}})$$

Table 5. Vout vs. R1 & R2 resistors value

Vout (Vrms)	Vout (dB μ V)	(R1+R2)/R2	R2 (K Ω)	R1 (K Ω)
0.150	103.5	1.1	7.5	1.0
0.250	108.0	1.9	5.1	3.9
0.350	110.9	2.7	3.6	5.6
0.500	114.0	3.7	3.3	8.2
0.625	115.9	4.7	3.3	11.0
0.750	117.5	5.8	2.7	12.0
0.875	118.8	6.6	2.0	11.0
1.000	120.0	7.6	1.6	10.0
1.250	121.9	9.5	1.6	13.0
1.500	123.5	10.8	1.6	15.0

Notes: The rate of R2 takes in account the input resistance on the SENSE pin (36 K Ω).
5.6nF capacitor effect has been neglected.

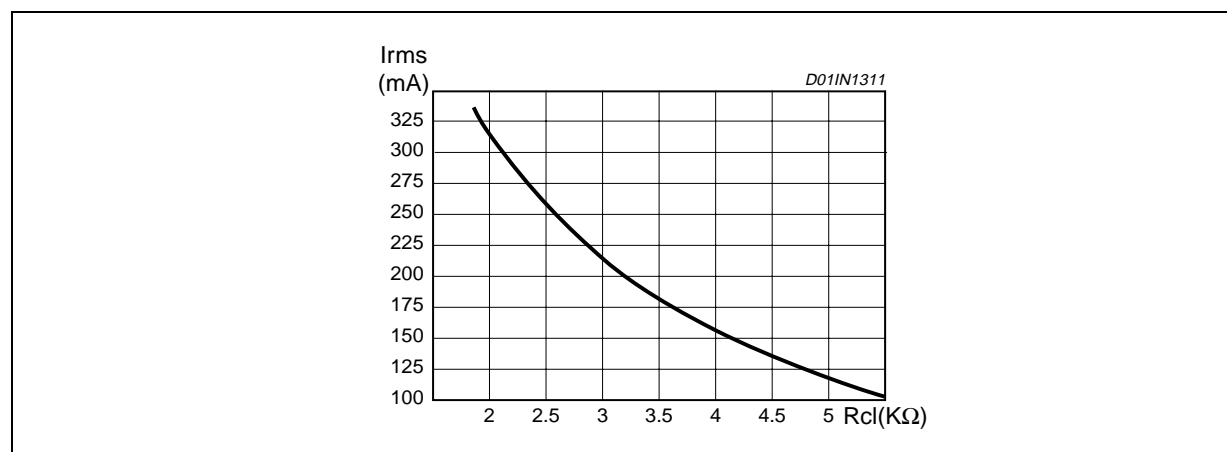
Figure 14. Typical Output Current vs. Rcl

■ Integrated Power Line Interface (PLI)

The Power Line Interface (PLI) is a double CMOS AB Class Power Amplifier with the two outputs (ATOP1 and ATOP2) in opposition of phase.

Two are the possible configuration:

- Single Ended Output (ATOP1).
- Bridge Connection

The Bridge connection guarantee a Differential Output Voltage to the load with twice the swing of each individual Output. This topology virtually eliminates the even harmonics generation.

The PLI requires, to ensure a proper operation, a regulated and well filtered Supply Voltage. PAVcc Voltage must fulfil the following formula to work without clipping phenomena:

$$PAV_{CC} \geq \frac{V_{ATOP(AC)}}{2} + 7.5V$$

To allow the driving of an external Power Line Interface, the output of the ALC is available even on ATO pin. ATO output has a current capability much lower than ATOP1 and ATOP2.

Figure 15. PLI Bridge Topology

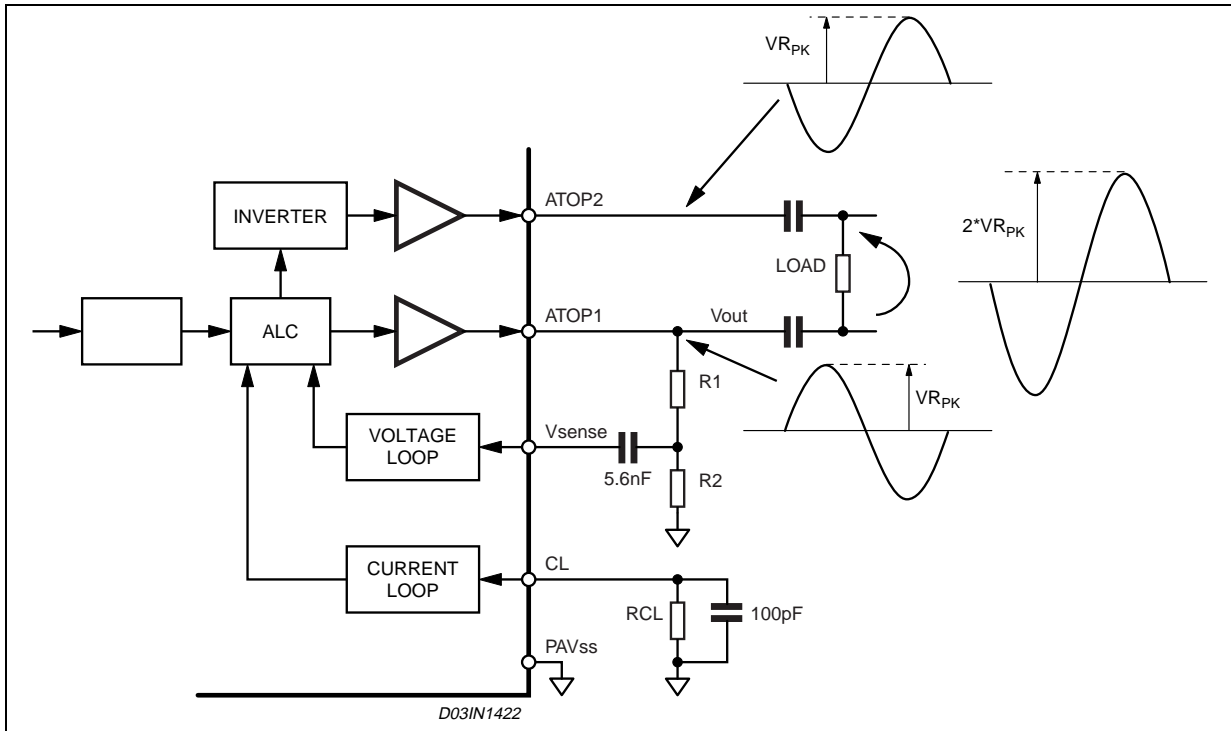
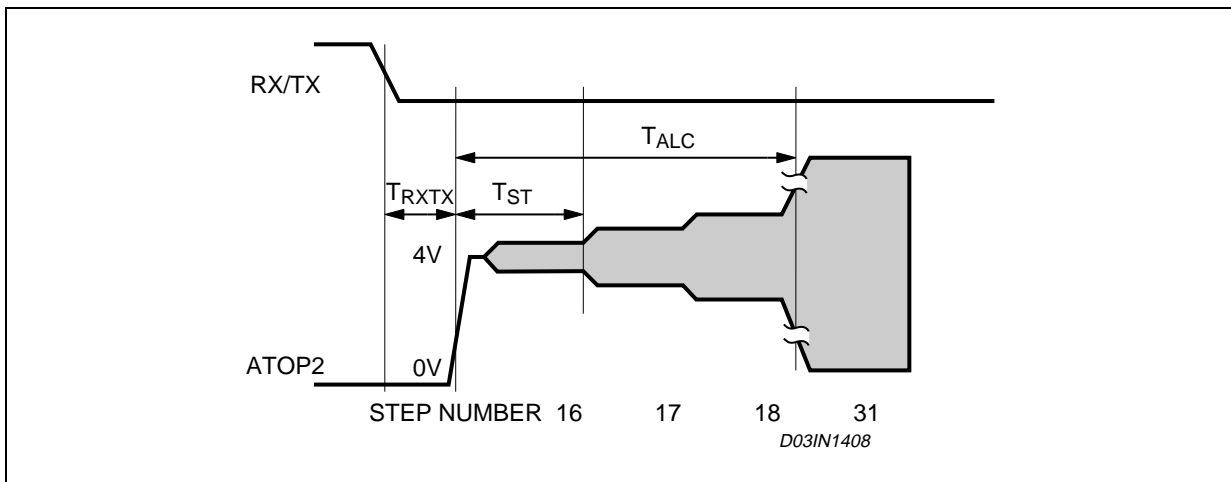

Figure 16. PLI Startup Timing Diagram



Control Register

The ST7538 is a multi-channel and multifunction transceiver. An internal 24 Bits Control Register allows to manage all the programmable parameters (table 5).

The programmable functions are:

- Channel Frequency
- Baud Rate
- Deviation
- Watchdog
- Transmission Timeout
- Frequency Detection Time
- Zero Crossing Synchronization
- Detection Method
- Mains Interfacing Mode
- Output Clock
- Packet Mode Baudrate
- Packet Length
- Packet Enable
- Input Pre-Filter
- Sensitivity Mode

Table 6. Control Register Functions

	Function	Value	Selection			Note	Default
			Bit2	Bit1	Bit0		
0 to 2	Frequencies	60 KHz 66 KHz 72 KHz 76 KHz 82.05 KHz 86 KHz 110 KHz 132.5 KHz	0	0	0		132.5 kHz
			0	0	1		
			0	1	0		
			0	1	1		
			1	0	0		
			1	0	1		
			1	1	0		
			1	1	1		
3 to 4	Baud Rate	600 1,200 2,400 4,800	Bit 4		Bit 3		2400
			0	0			
			0	1			
			1	0			
5	Deviation	0.5 1	Bit 5			0.5	
			0	1			
6	Watchdog	Disabled Enabled (1.5 s)	Bit 6			Enabled	
			0	1			
7 to 8	Transmission Time Out	Disabled 1 s 3 s Not Used	Bit 8		Bit 7		1 sec
			0	0			
			0	1			
			1	0			
9 to 10	Frequency detection time	500 μ s 1 ms 3 ms 5 ms	Bit 10		Bit 9		1 ms
			0	0			
			0	1			
			1	0			
11	Zero Crossing Synchronization	Disabled Enabled	Bit 11			Disabled	
			0	1			

Table 6. Control Register Functions (continued)

	Function	Value	Selection		Note	Default	
			Bit 13	Bit 12			
12 to 13	Detection Method	Carrier detection without conditioning	0	0	Carrier Detection Notification on CD_PD Line CLR/T and RxD signal always Present	Preamble detection without conditioning	
		Carrier detection with conditioning	0	1	CLR/T and RxD lines are forced to "0" when Carrier is not detected		
		Preamble detection without conditioning	1	0	Preamble Detection Notification on CD_PD Line CLR/T and RxD signal always Present		
		Preamble detection with conditioning	1	1	Preamble Detection Notification on CD_PD Line CLR/T and RxD lines are forced to "0" when Preamble has not been detected or PLL is in Unlock condition		
14	Mains Interfacing Mode	Synchronous Asynchronous	Bit 14			Asynchronous	
			0	1			
15 to 16	Output Clock	16 MHz 8 MHz 4 MHz Not Used	Bit 16		Bit 15		4 MHz
			0	0	0	1	
			1	0	1	0	
			1	1	1	1	
17 to 18	Packet Mode Baud Rate	Mclk/32 Mclk/64 Mclk/128 Mclk/256	Bit 18		Bit 17		MLCK/64
			0	0	0	1	
			1	0	1	0	
			1	1	1	1	
19 to 20	Packet Length	8 Bit 9 Bit 14 Bit 16 Bit	Bit 20		Bit 19		14 bits
			0	0	0	1	
			1	0	1	0	
			1	1	1	1	
21	Packet Mode Enable	Disabled Enabled	Bit 21			Disabled	
			0	1			
22	Sensitivity Mode	Normal Sensitivity High Sensitivity	Bit 22			Normal	
			0	1			
23	Input Filter	Disabled Enabled	Bit 23			Disabled	
			0	1			

AUXILIARY ANALOG AND DIGITAL FUNCTIONS

Band In Use

The Band in Use Block has a Carrier Detection like function but with a different Input Sensibility (77dB μ V Typ.)

and with a different BandPass filter Selectivity (40dB/Dec).

BU line is forced High when a signal in band is detected.

To prevent BU line false transition, BU signal is conditioned to Carrier Detection Internal Signal.

Time Out

Time Out Function is a protection against a too long data transmission. When Time Out function is enabled after 1 or 3 second of continuous transmission the transceiver is forced in receiving mode. This function allows ST7538 to automatically manage the CENELEC Medium Access specification. When a time-out event occur, TOUT is forced high, and is held high for at least 125 ms. To Unlock the Time Out condition RxTx should be forced High. During the time out period only register access or reception mode are enabled.

During Reset sequence if RxTx line = "0" & REG_DATA line = "1", TIMEOUT protection is suddenly enabled and ST7538 must be configured in data reception after the reset event before starting a new data transmission.

Time Out time is programmable using Control Register bits 7 and 8 (table 6).

Figure 17. Time-out Timing and Unlock Sequence

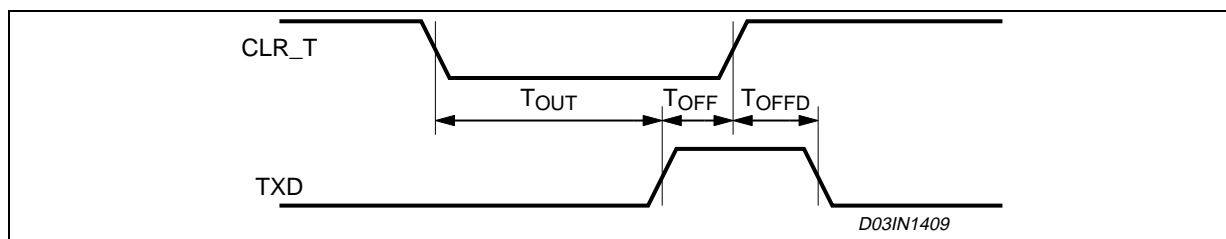

Reset & Watchdog

RSTO Output is a reset generator for the application circuitry. During the ST7538 startup sequence is forced low. RSTO becomes high after a TRSTO delay from the end of oscillator startup sequence.

Inside ST7538 is also embedded a watchdog function. The watchdog function is used to detect the occurrence of a software fault of the Host Controller. The watchdog circuitry generates an internal and external reset (RSTO low for TRSTO time) on expiry of the internal watchdog timer. The watchdog timer reset can be achieved applying a negative transition on WD pin Fig 18.

Figure 18. Reset and Watchdog Timing

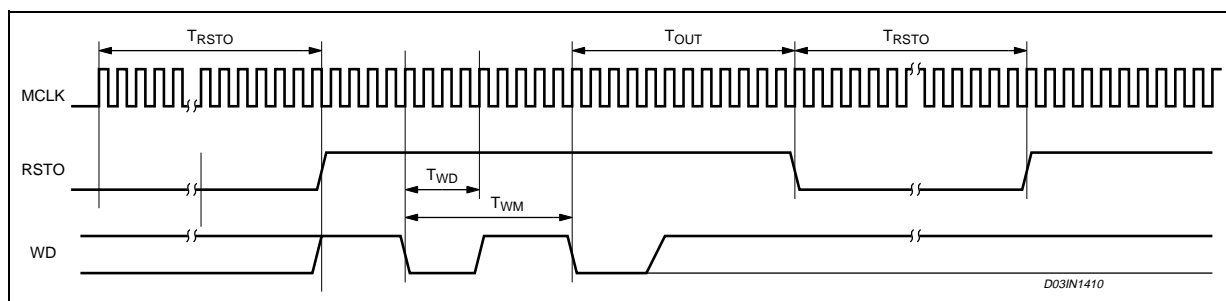

Zero Crossing Detection

The Mains Voltage Zero Crossing can be detected, through a proper connection of ZCIN to the Mains. ZCIN comparator has a threshold fixed at SGND. ZCOUT is a TTL Output forced High after a positive zero-crossing transition, and low after a negative one.

Setting the Bit 11 inside the Control Register to "1" the transmission is automatically synchronized to the mains positive zero-crossing transition. This function is achieved turning on the PLI when RX/TX is low and delaying the CLR/T first transition until the first zero-crossing event. The automatic synchronization procedure can work only if the synchronous interface is programmed. If asynchronous interface is in use the Zero Crossing synchronization can be achieved managing the ZCOUT line.

Figure 19. Synchronous Zero-Crossing Transmission

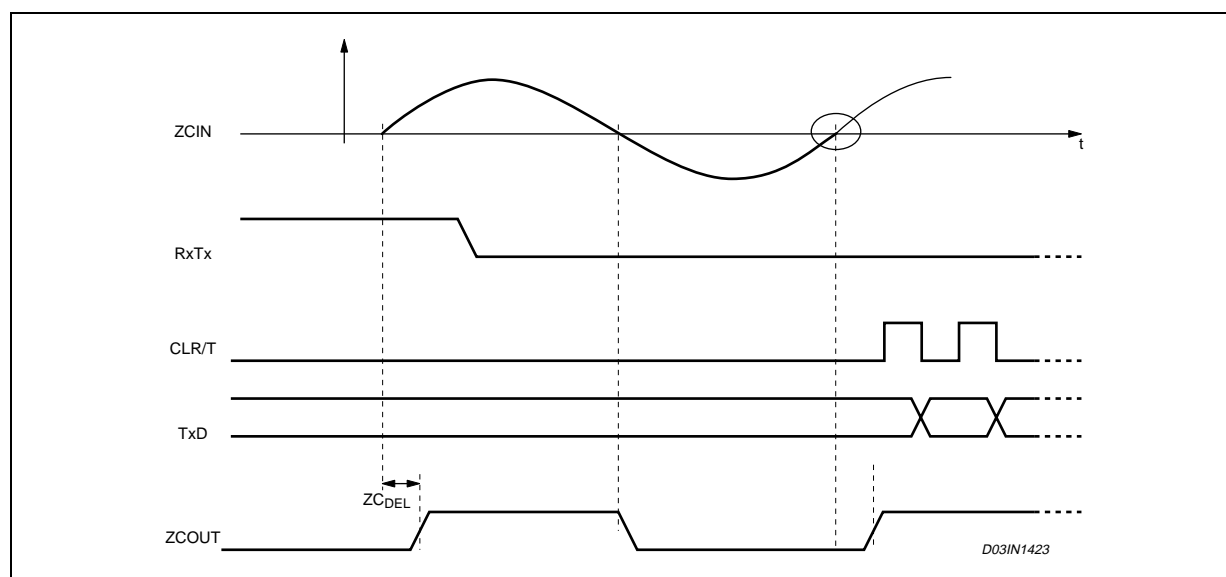

Output Clock

MCLK is the master clock output. The clock frequency sourced can be programmed through the control register to be a ratio of the crystal oscillator frequency (F_{osc} , $F_{osc}/2$ $F_{osc}/4$). The transition between one frequency and another is done only at the end of the ongoing cycle.

Reg OK

REGOK allows to detect an undesired modification of the control register content. REGOK function is disabled during a control register writing session.

Under Voltage Lock Out

The UVLO function turns off the device if the PAVdd voltage falls under 4V. Hysteresis is 250mV typically.

Thermal Shutdown

The ST7538 is provided of a thermal protection which turn off the PLI when the junction temperature exceeds $170^{\circ}\text{C} \pm 10\%$. Hysteresis is around 30°C .

When shutdown threshold is overcome, PLI interface is switched OFF.

Thermal Shutdown event is notified to the HOST controller using TIMEOUT line. When TIMEOUT line is High, ST7538 junction temperature exceed the shutdown threshold (Not Latched).

5V Voltage Regulator and Power Good Function

ST7538 has an embedded 5V linear regulator externally available to supply the application circuitry.

The linear regulator has a very low quiescent current ($50\mu\text{A}$) and a current capability of 100mA. The regulator is protected against short circuiting events.

When the regulator Voltage is above the power good threshold (V_{PG}), Power Good line is forced high, while is forced low at startup and when VDC falls below $V_{PG} - V_{PGHYS}$ Voltage.

Figure 20. Power Good Function

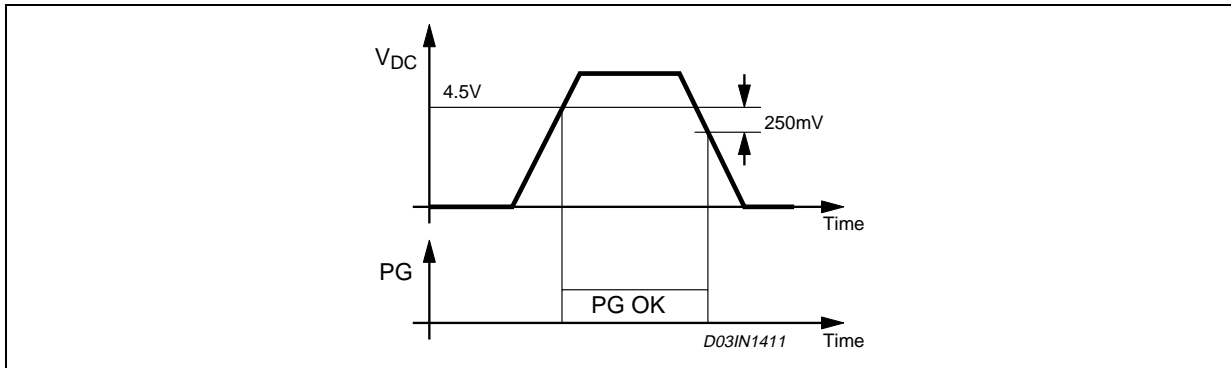

Power-Up Procedure

To ensure ST7538 proper power-Up sequence, PAVcc, AVss and DVss Supply has to fulfil the following rules:

PAVcc rising slope must not exceed 10V/ms.

When DVdd and AVdd are below 5V: $100\text{mV} < \text{PAVcc-AVdd}$, $\text{PAVcc-DVdd} < 1.2\text{V}$.

When AVdd and DVdd supply are connected to VDC the above mentioned relation is guaranteed if VDC load $< 100\text{mA}$ and if the filtering capacitor on VDC $< 100\mu\text{F}$.

Figure 21. Power-UP Sequence

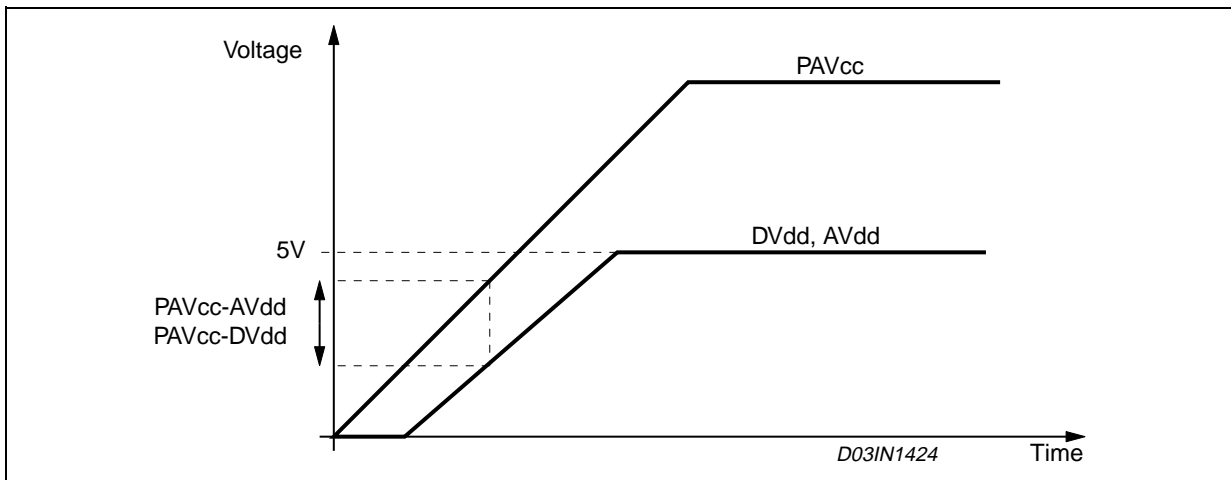

PACKAGE INFORMATION

Best thermal performance is achieved when slug is soldered to PCB. It is recommended to have five solder dots (See fig. 22) without resist to connect the Copper slug to the ground layer on the soldering side. Moreover it is recommended to connect the ground layer on the soldering side to another ground layer on the opposite side with 15 to 20 vias.

Figure 22. Application Schematic Example with Coupling Transformer.

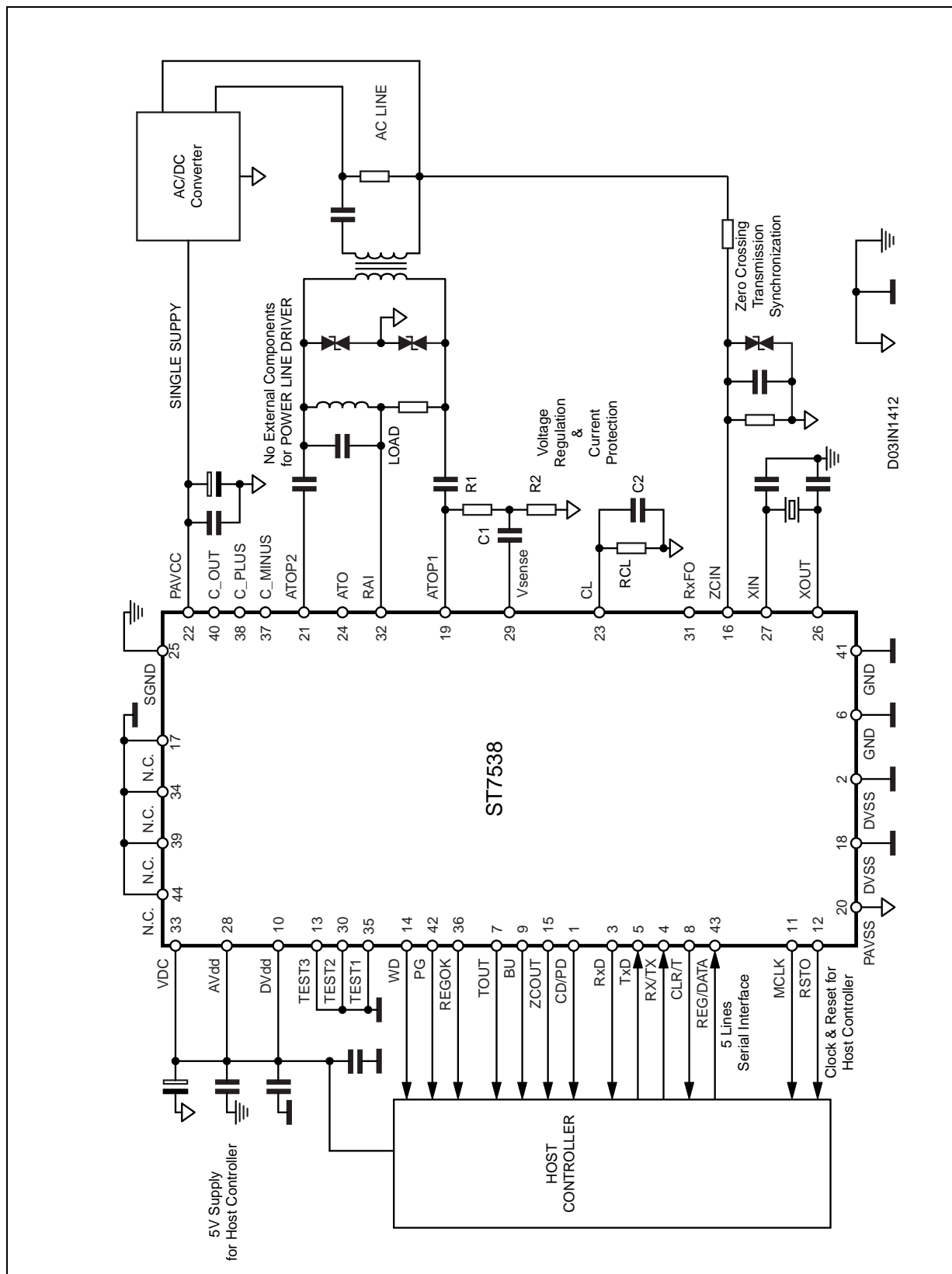

Figure 23. ST7538 Slug Drawing

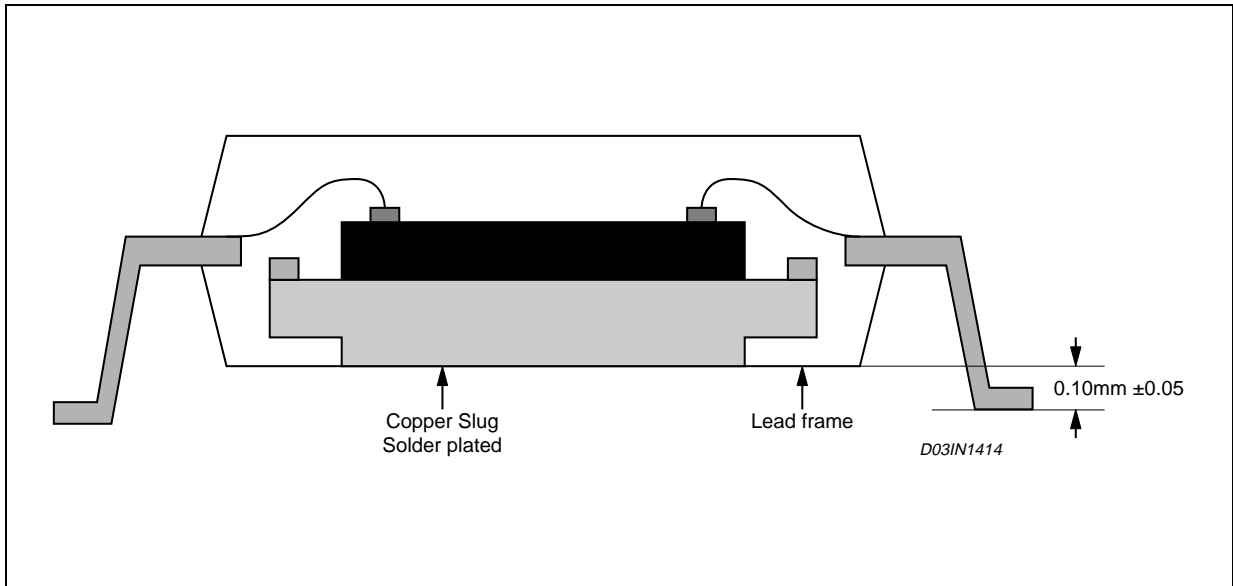

Figure 24. Soldering Information

Package Sizes	10x10x1.4mm
A	2.00 mm
B	1.00 mm
L	6.00 mm
L1 (Copper plate)	10.00 mm

If PCB with ground layer, connect copper plate with 15 to 20 vias

DIM.	mm			inch		
	MIN.	TYP.	MAX.	MIN.	TYP.	MAX.
A			1.60			0.063
A1	0.05		0.15	0.002		0.006
A2	1.35	1.40	1.45	0.053	0.055	0.057
b	0.30	0.37	0.45	0.012	0.014	0.018
c	0.09		0.20	0.003		0.008
D	11.80	12.00	12.20	0.464	0.472	0.480
D1	9.80	10.00	10.20	0.386	0.394	0.401
D3		8.00			0.315	
e		0.80			0.031	
E	11.80	12.00	12.20	0.464	0.472	0.480
E1	9.80	10.00	10.20	0.386	0.394	0.401
E3		8.00			0.315	
H		5.89			0.232	
L	0.45	0.60	0.75	0.018	0.024	0.030
L1		1.00			0.039	
S	6.00			0.236		
S1	6.00			0.236		
K	0° (min.), 3.5° (typ.), 7° (max.)					
ccc			0.10			0.004

OUTLINE AND MECHANICAL DATA

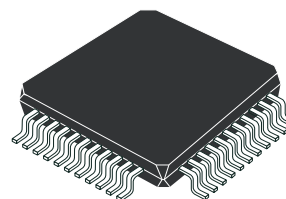

TQFP44 (10x10x1.40mm) with Slug Down

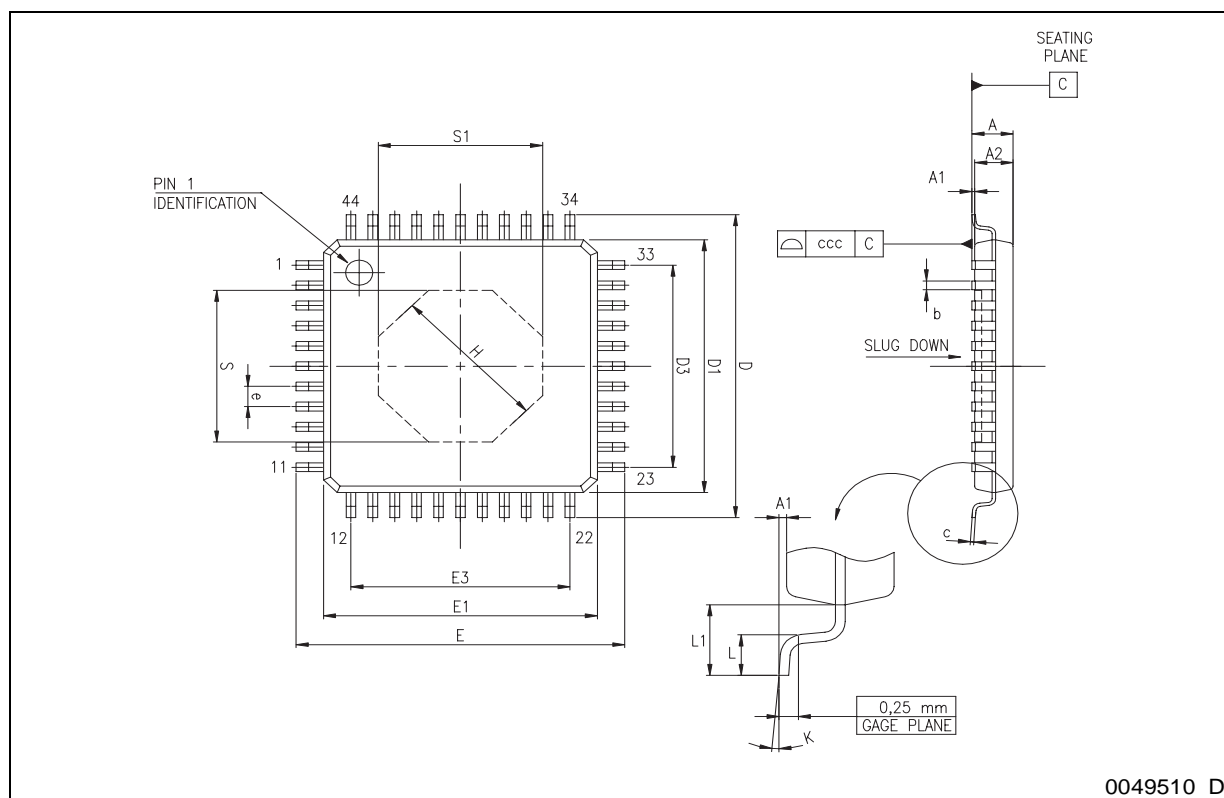

Information furnished is believed to be accurate and reliable. However, STMicroelectronics assumes no responsibility for the consequences of use of such information nor for any infringement of patents or other rights of third parties which may result from its use. No license is granted by implication or otherwise under any patent or patent rights of STMicroelectronics. Specifications mentioned in this publication are subject to change without notice. This publication supersedes and replaces all information previously supplied. STMicroelectronics products are not authorized for use as critical components in life support devices or systems without express written approval of STMicroelectronics.

The ST logo is a registered trademark of STMicroelectronics
© 2003 STMicroelectronics - All Rights Reserved

STMicroelectronics GROUP OF COMPANIES
Australia - Brazil - Canada - China - Finland - France - Germany - Hong Kong - India - Israel - Italy - Japan -Malaysia - Malta - Morocco -
Singapore - Spain - Sweden - Switzerland - United Kingdom - United States.
<http://www.st.com>

This datasheet has been download from:

www.datasheetcatalog.com

Datasheets for electronics components.